

CHB150



99 TO 150 WATT WIDE INPUT DC-DC CONVERTERS SINGLE OUTPUT



Feature

- 99-150W Isolated Output
- Efficiency to 85%
- 500KHz Switching Frequency
- 2 : 1 Input Range
- Regulated Outputs
- Continuous Short Circuit Protection
- Five-Sided Metal Case
- Half-Brick size meet industrial standard

MODEL NUMBER	INPUT VOLTAGE	OUTPUT VOLTAGE	OUTPUT CURRENT	INPUT CURRENT NO LOAD	INPUT CURRENT FULL LOAD	%EFF	CASE
CHB150-48S33	36-75 VDC	3.3 VDC	30A	25 mA	2.6A	79	HB
CHB150-48S05	36-75 VDC	5 VDC	30A	25 mA	3.7A	83	HB
CHB150-48S12	36-75 VDC	12 VDC	12.5A	25 mA	3.6A	85	HB
CHB150-48S15	36-75 VDC	15 VDC	10A	25 mA	3.6A	85	HB

NOTE : 1. Nominal Input Voltage 48 VDC

Specifications

All Specifications Typical At Nominal Line , Full Load , and 25°C Unless Otherwise Noted

INPUT SPECIFICATIONS:

Input Voltage Range..... 48V.....36-75V
 Undervoltage lockout 48Vin power up 34V
 48Vin power down 32.5V
 Positive Logic Remote ON/OFF ^{3,4}
 Input Filter PI Type

OUTPUT SPECIFICATIONS:

Voltage Accuracy : ±1% max.
 Transient Response :25% Step Load Change<500µ sec.
 External Trim Adj. Range±10%
 Ripple & Noise, 20MHz BW, 3.3V & 5V 40mV RMS., max.
 100mV pk-pk, max.
 12V & 15V 60mV RMS., max.
 150mV pk-pk, max.
 Temperature Coefficient..... ±0.03%/°C
 Short Circuit Protection.....Continuous
 Line Regulation¹±0.2% max.
 Load Regulation²±0.2% max.
 Over Voltage Protection trip Range ,% Vo nom.115-140%
 Current Limit110% ~140% Nominal Output

GENERAL SPECIFICATIONS:

Efficiency.....See Table
 Isolation VoltageInput/Output..... 1500VDC min.
 Input/Case..... 1500VDC min.
 Output/Case..... 1500VDC min.
 Isolation Resistance 10⁷ ohm min.
 Switching Frequency 500KHz ,Typ.
 Operating case Temperature -40°C to 100°C
 Storage Temperature -40°C to +105°C
 Thermal Shutdown Range, Case Temp.100°C to 110°C
 Dimensions2.28x2.40x0.50 inches
 (57.9x61.0x12.7 mm)
 Case MaterialAluminum

NOTE:

1. Measured From High Line to Low Line.
2. Measured From Full Load to Zero Load.
3. Logic Compatibility Open Collector ref to -Input
 Module ON Open Circuit
 Module OFF < 0.8Vdc
4. Suffix "N" to the Model Number with Negative Logic Remote ON/OFF.

CASE HB

All Dimensions In Inches(mm)

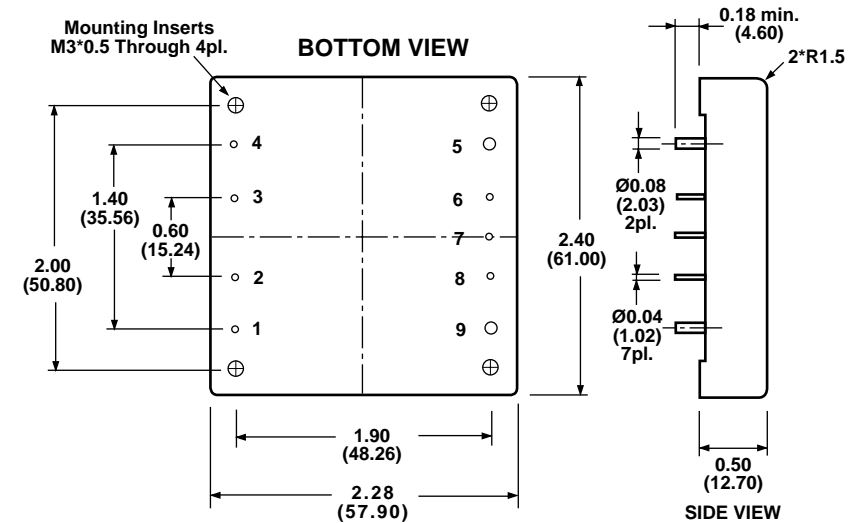

PIN CONNECTION	
Pin	Function
1.	+Vin
2.	ON/OFF
3.	CASE
4.	-Vin
5.	-Vout
6.	-Sense
7.	Trim
8.	+Sense
9.	+Vout

Tolerances	Inches	.XX±0.02	.XXX±0.01	Pin
	Millimeters	.X±0.5	.XX±0.25	±0.02 ±0.5

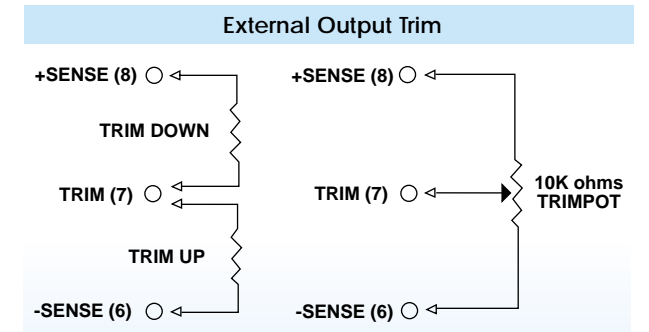
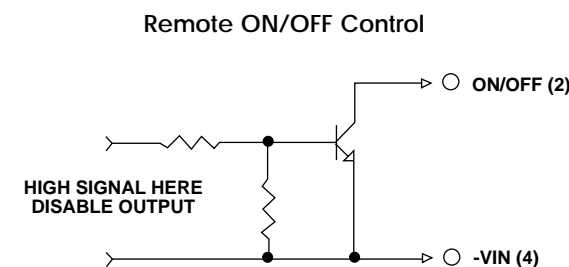

Application Note

Derating

The operating case temperature range of CHB100/150 series is -40°C to +100°C. When operating the CHB100/150 series, proper derating or cooling is needed.

The following curve is the derating curve of CHB100/150 without heat sink.

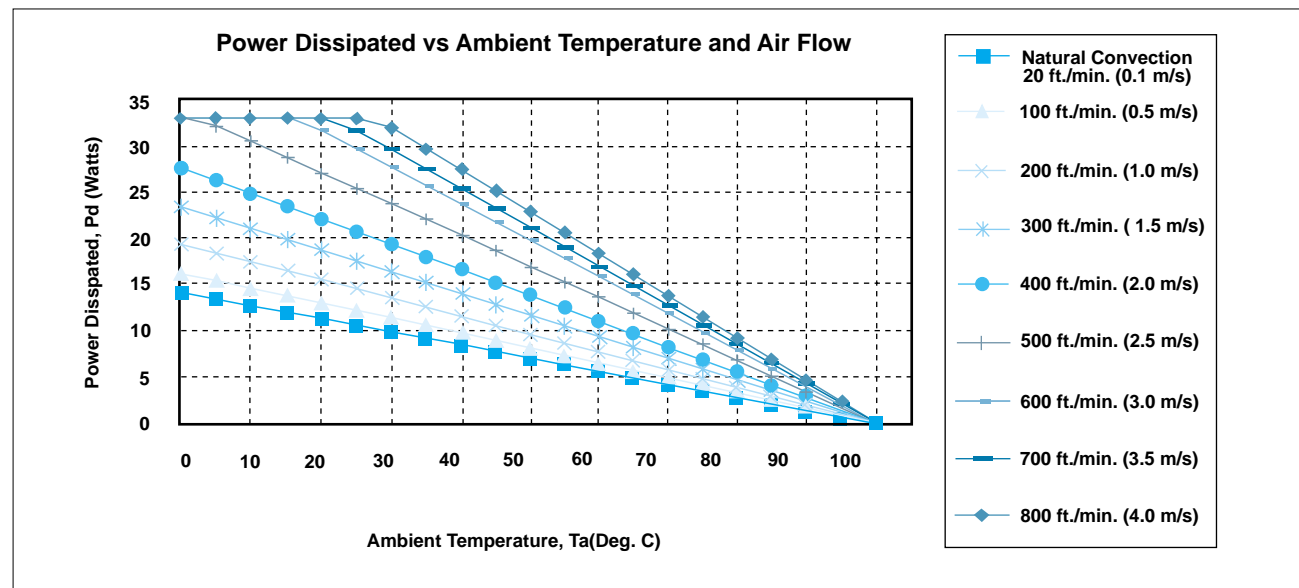

Forced Convection Power Derating with No Heat Sink

Where:

The power dissipation (Pd):

$$Pd = Pi - Po = Po (1 - \eta) / \eta$$

The thermal resistance are list below:

Chart of Thermal Resistance vs Air Flow:

AIR FLOW RATE	TYPICAL Rca
Natural Convection 20ft./min. (0.1m/s)	7.12 °C/W
100 ft./min. (0.5m/s)	6.21 °C/W
200 ft./min. (1.0m/s)	5.17 °C/W
300 ft./min. (1.5m/s)	4.29 °C/W
400 ft./min. (2.0m/s)	3.64 °C/W
500 ft./min. (2.5m/s)	2.96 °C/W
600 ft./min. (3.0m/s)	2.53 °C/W
700 ft./min. (3.5m/s)	2.37 °C/W
800 ft./min. (4.0m/s)	2.19 °C/W

The temperature rise (ΔT):

$$\Delta T = Pd * Rca$$

Remote ON/OFF Control

The CHB100/150 Series allow the user to switch the module on and off electronically by remote on/off feature. The CHB100/150 Series are available in "positive logic" or "negative logic" (option) versions for remote on/off.

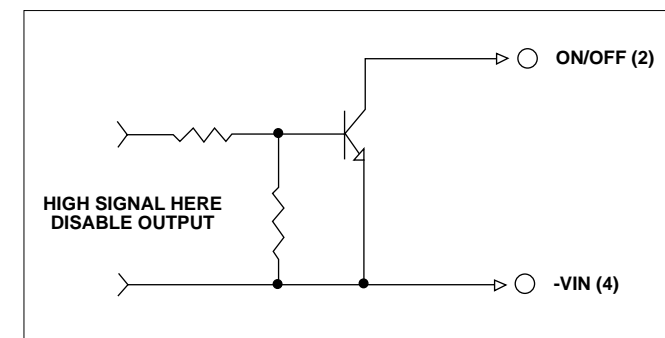

Logic Table

Logic State (Pin 2)	Negative Logic	Positive Logic
Logic Low - Switch Closed	Module on	Module off
Logic High - Switch Open	Module off	Module on

External Output Trimming

Output may optionally be externally trimmed ($\pm 10\%$) with a fixed resistor or an external trimpot as shown.

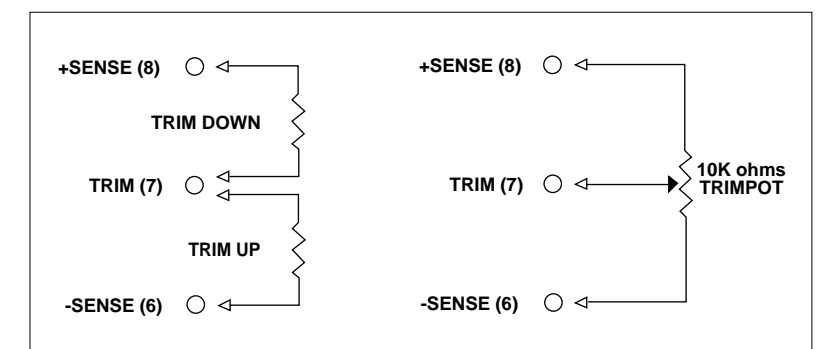

External Output

Output Noise

The output noise is measured with 10 μ F tantalum capacitor and 1.0 μ F ceramic capacitor across output.

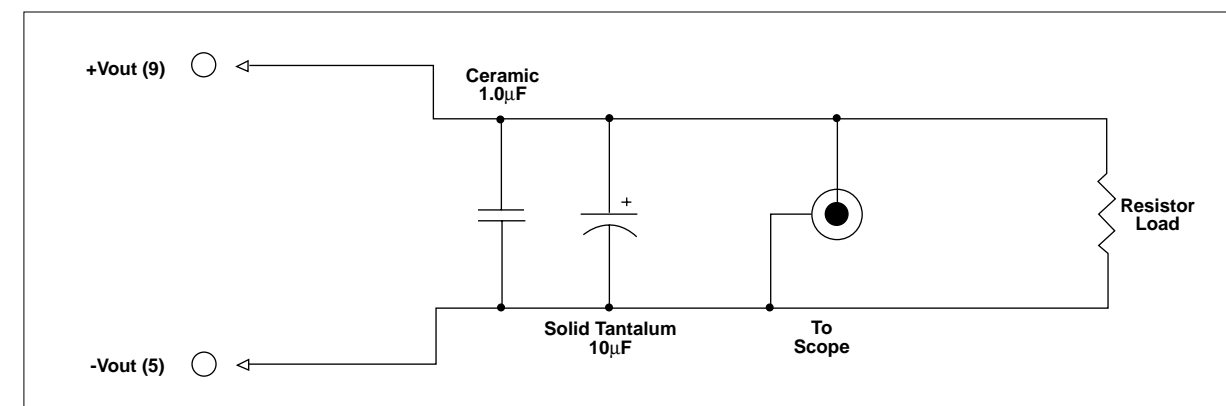

Output Noise Test Circuit schematic