



MEAN WELL

SWITCHING POWER SUPPLY
ISO-9001 CERTIFIED MANUFACTURER

PT-4503

- .LOW COST, HIGH RELIABILITY
- .105°C OUTPUT CAPACITOR
- .INTERNATIONAL AC INPUT RANGE
- .HIGH EFFICIENCY, LOW WORKING TEMPERATURE
- .SOFT-START CIRCUIT, LIMITING AC SURGE CURRENT
- .SHORT CIRCUIT, OVERLOAD, OVER VOLTAGE PROTECTED
- .COMPACT SIZE, LIGHT WEIGHT
- .100% FULL LOAD BURN-IN TEST
- .BUILT IN EMI FILTER, LOW RIPPLE NOISE



MODEL	CH1	CH2	CH3
SPECIFICATION			
DC OUTPUT VOLTAGE	3.3V	5V	12V
OUTPUT V. TOLERANCE	±2%	+4,-2%	±8%
OUTPUT RATED CURRENT	4A	4A	1A
OUTPUT CURRENT RANGE	0-5A	0.2-7A	0-1.2A
RIPPLE & NOISE	50mV	50mV	100mV
LINE REGULATION	±1%	±1%	±2%
LOAD REGULATION	±2%	±2%	±8%
RATED OUTPUT POWER	TOTAL POWER MAX. 45.2W (CH1+CH2 MAX. 35W)		
EFFICIENCY	72%		
DC VOLTAGE ADJ.	CH1:3-3.6V		
INPUT VOLTAGE RANGE	90~264VAC 47~63Hz; 120~370VDC		
AC CURRENT	1.2A/115V 0.7A/230V		
INRUSH CURRENT	COLD START 20A/115V 40A/230V		
LEAKAGE CURRENT	<1mA/240VAC		
OVERLOAD PROTECTION	120~160% PULSING MODE RESET:AUTO RECOVERY		
OVER VOLTAGE PROTECTION	115%~135% ON +5V		
TEMP. COEFFICIENT	±0.03% / °C (0~50°C)		
SETUP,RISE,HOLD UP TIME	800ms, 50ms, 16ms		
VIBRATION	10~500Hz, 2G 3AXES 10min. / 1cycle (1 HOUR / EACH AXES)		
WITHSTAND VOLTAGE	I/P-O/P:3KVAC I/P-FG:1.5KVAC O/P-FG:0.5KVAC 1min.		
ISOLATION RESISTANCE	I/P-O/P,I/P-FG,O/P-FG:500VDC / 100M Ohms		
WORKING TEMP., HUMIDITY	-10°C~+60°C(REFER TO OUTPUT DERATING CURVE), 20%~90% RH @		
STORAGE TEMP., HUMIDITY	-20°C~+85°C, 10%~95% RH		
DIMENSION	127*76.2*30mm (L*W*H) PCB ONLY		
WEIGHT	0.25Kgs		
SAFETY STANDARDS	UL1950,TUV EN60950 APPROVED		
EMC STANDARDS	EN50081-1, EN50082-1 VERIFICATION		

- NOTE :
- 1.ALL PARAMETERS ARE SPECIFIED AT 230VAC INPUT, RATED LOAD, 25°C 70% RH. AMBIENT.
 - 2.TOLERANCE GINCLUDE SET UP TOLERANCE, LINE REGULATION, LOAD REGULATION.
 - 3.RIPPLE & NOISE ARE MEASURED AT 20MHz BY USING A 12" TWISTED PAIR TERMINATED WITH A 0.1uF & 47uF CAPACITOR.
 - 4.LINE REGULATION IS MEASURED FROM LOW LINE TO HIGH LINE AT RATED LOAD.
 - 5.OUTPUT PROVIDE UP TO MAXIMUM CURRENT, BUT RELATED TO MAXIMUM OUTPUT POWER.
 - 6.MOUNTING HOLES M1 AND M2 SHOULD BE GROUNDED FOR EMI PURPOSES.

1999-09-02

BLOCK DIAGRAM

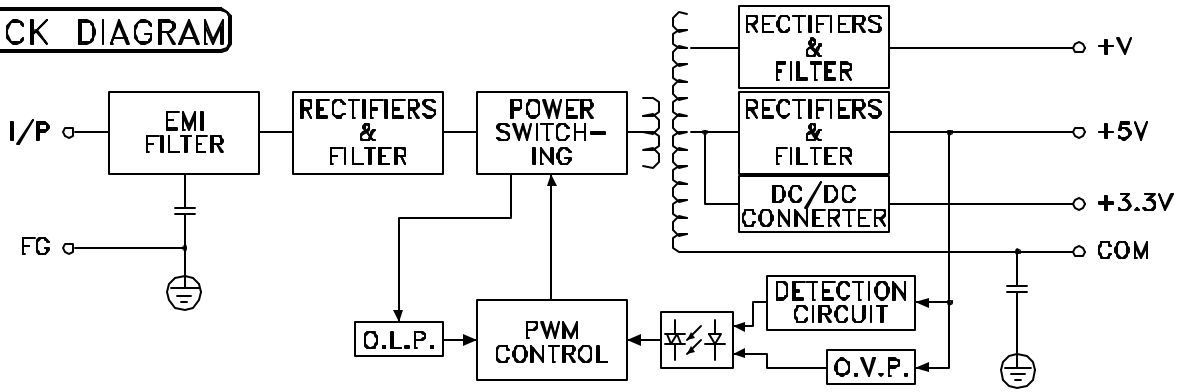

fosc : 65KHz

OUTPUT DERATING

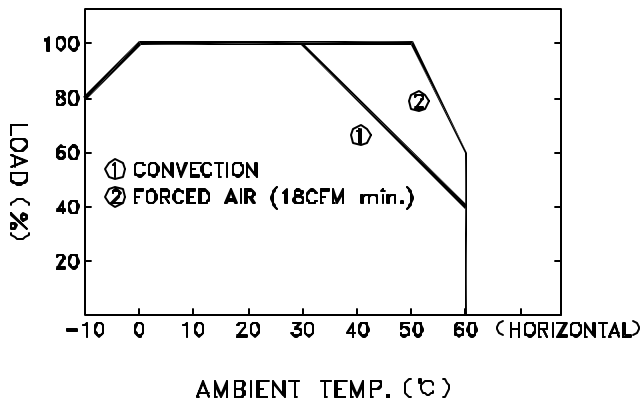

STATIC CHARACTERISTICS

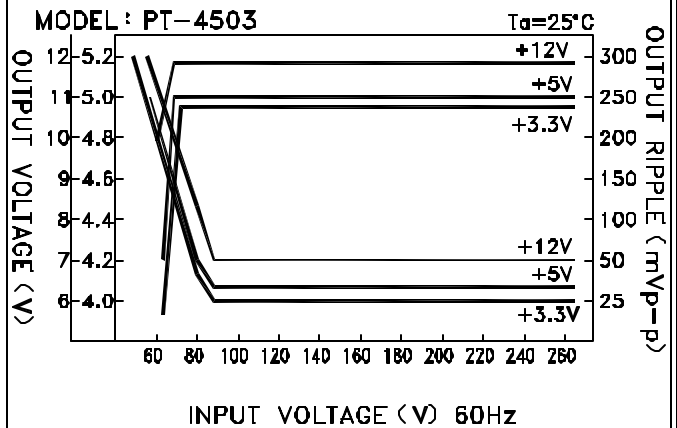

DIMENSION (mm)

☒ TERMINAL PIN NO. ASSIGNMENT

- ☒ CN1 : AC INPUT
- ☒ CN2 : DC OUTPUT
- ☒ PIN 1,2 : DC OUTPUT +5V
- ☒ PIN 3,4,5: DC OUTPUT COM
- ☒ PIN 6 : DC OUTPUT +V
- ☒ PIN 7,8 : DC OUTPUT +3.3V

