



MEAN WELL

SWITCHING POWER SUPPLY
ISO-9001 CERTIFIED MANUFACTURER

SD-150 SERIES

- .LOW COST, HIGH RELIABILITY
- .105°C OUTPUT CAPACITOR
- .BUILT IN EMI FILTER, LOW RIPPLE NOISE
- .HIGH EFFICIENCY, LOW WORKING TEMPERATURE
- .COMPACT SIZE, LIGHT WEIGHT
- .SHORT CIRCUIT, OVERLOAD, OVER VOLTAGE PROTECTED

.100% FULL LOAD BURN-IN TEST



MODEL	SD-150B-12	SD-150C-12	SD-150D-12	SD-150B-24	SD-150C-24	SD-150D-24
SPECIFICATION						
DC OUTPUT VOLTAGE	12V			24V		
OUTPUT V. TOLERANCE	±1%			±1%		
OUTPUT RATED CURRENT	12.5A			6.3A		
OUTPUT CURRENT RANGE	0-12.5A			0-6.3A		
RIPPLE & NOISE	120mVp-p			150mVp-p		
LINE REGULATION	±0.5%			±0.3%		
LOAD REGULATION	±0.5%			±0.3%		
DC OUTPUT POWER	150W			151.2W		
EFFICIENCY	75%	77%	79%	77%	80%	82%
DC VOLTAGE ADJ.	11-16V			23-30V		
INPUT VOLTAGE RANGE	B:19~36VDC C:36~72VDC D:72~144VDC or 85~132VAC					
INPUT CURRENT	B:8.5A/24VDC C:4.2A/48VDC D:2.1A/96VDC					
INRUSH CURRENT	B,C:----- D:25A/96VDC					
LEAKAGE CURRENT	<0.75mA/120VAC (SD-150D)					
OVERLOAD PROTECTION	105%~135% TYPE:FOLDBACK CURRENT LIMITING RESET:AUTO RECOVERY					
OVER VOLTAGE PROTECTION	16.8V~20V/10% LOAD			31.5V~37.5V/10% LOAD		
OVER TEMP. PROTECTION	-----					
TEMP. COEFFICIENT	±0.03% / °C (0~50°C)					
SETUP, RISE, HOLD UP TIME	2s, 50ms, 10ms/20ms (ONLY D MODE)					
VIBRATION	10~500Hz, 2G 10min./1cycle, PERIOD FOR 60min. EACH AXES					
WITHSTAND VOLTAGE	I/P-O/P:1.5KVAC I/P-FG:1.5KVAC O/P-FG:0.5KVAC					
ISOLATION RESISTANCE	I/P-O/P, I/P-FG, O/P-FG:500VDC / 100M Ohms					
WORKING TEMP., HUMIDITY	-10°C~+60°C(REFER TO OUTPUT DERATING CURVE), 20%~90% RH					
STORAGE TEMP., HUMIDITY	-20°C~+85°C, 10%~95% RH					
DIMENSION	199*110*50mm CASE:906					
WEIGHT	0.85Kgs					
SAFETY STANDARDS	-----					
EMC STANDARDS	EN55022 CLASS B (RADIATION), EN61000-4-2,3,4,6,8 ENV50204 VERIFICATION FOR SD-150B/C SERIES ONLY, NOT INCLUDING SD-150D SERIES.					

- NOTE :
- 1.ALL PARAMETERS ARE SPECIFIED AT RATED INPUT, RATED LOAD, 25°C 70% RH. AMBIENT.
 - 2.TOLERANCE GINCLUDE SET UP TOLERANCE, LINE REGULATION, LOAD REGULATION.
 - 3.RIPPLE & NOISE ARE MEASURED AT 20MHz BY USING A 12" TWISTED PAIR TERMINATED WITH A 0.1uF & 47uF CAPACITOR.
 - 4.LINE REGULATION IS MEASURED FROM LOW LINE TO HIGH LINE AT RATED LOAD.
 - 5.LOAD REGULATION IS MEASURED FROM 0% TO 100% RATED LOAD.

BLOCK DIAGRAM

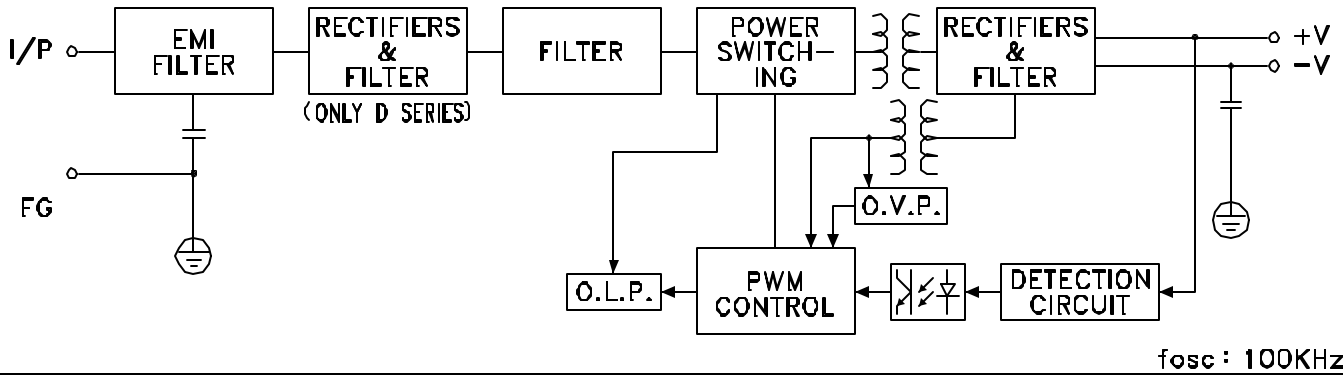

OUTPUT DERATING

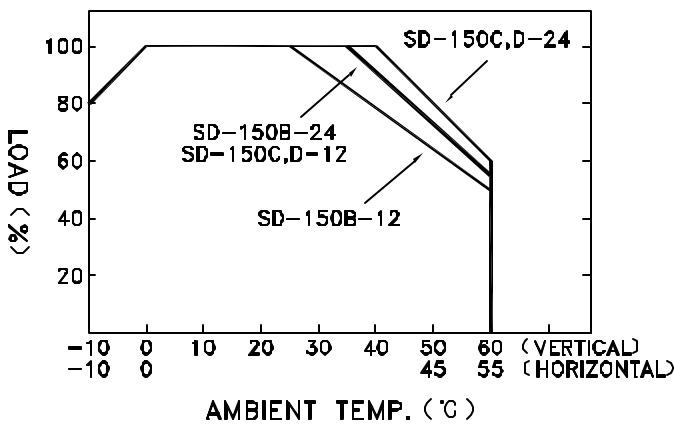

STATIC CHARACTERISTICS

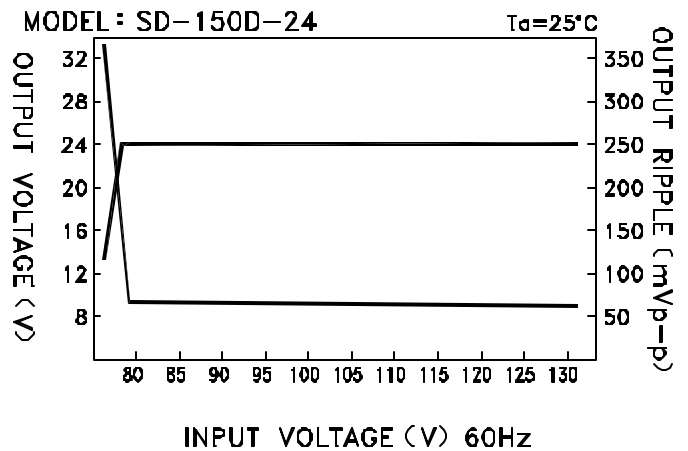

DIMENSION (mm)

- ☒ CASE : 906
- ☒ TERMINAL PIN NO. ASSIGNMENT
- ☒ PIN 1,2 : INPUT ※
- ☒ PIN 3 : FG ⊕
- ☒ PIN 4,5 : DC OUTPUT -V
- ☒ PIN 6,7 : DC OUTPUT +V
- ※SD-150B,C
- ☒ PIN 1 : DC INPUT V+
- ☒ PIN 2 : DC INPUT V-
- ※SD-150D
- ☒ PIN 1,2 : AC/DC INPUT

