



### KEY FEATURES

---

- High Density: 1RU by 2RU Package
- High Efficiency, 92% Typical
- Wide Temp. Range: -40 to 60 C
- Parallel Redundant Operation
- Hot Bus Pluggable
- Integral EMI Filtering
- Configurable Signal Interface

### BENEFITS

---

- Flexible geometry for rack applications
- Minimal rack space
- Limited Heat Dissipation
- Minimal Battery Overhead
- Ideal for remote shelters
- Scalable
- Interoperable with most DC Systems

### OVERVIEW

---

The Intermediate Bus Converter (IBC) is a modular hot plug-in, scalable DC to DC converter that provides a well regulated and isolated output voltage. These modules are designed to operate from a variable DC input source making them suitable for both positive and negative outputs from 24V battery systems. The product was designed specifically for modern wireless communications power systems where battery back up is required along with multiple output voltages. The converter is designed to operate stand-alone or in parallel redundant applications with up to 4kW in a 1RU 19" power shelf or 8kW of power in a 2RU by 19" power shelf.

## SPECIFICATIONS

### INPUT

Nominal Inputs: 24VDC Battery  
 Input Range: 19.5 – 30 VDC  
 Input Current: 60A max.  
 Peak Inrush Current: 20A (no load)  
 Internal Fuse Protection Provided.

### OUTPUT

Voltage: -49VDC Nominal  
 Current: 20.8 A  
 Regulation: +/- 2%, Line & Load  
 Isolation: 1500VDC Input to Output.  
 100 VDC Input to Ground

Active Current Share

### POWER RATING

1.0kW Max, over full temperature range

### EFFICIENCY

Efficiency: 92% Typical

### ELECTRONIC CONTROL I/O

Remote Inhibit: TTL Compatible  
 Overtemp Alarm: TTL Compatible  
 Output Failure Alarm: TTL Compatible

### PROTECTION

Input Undervoltage  
 Output Overload / Short-Circuit  
 Over Temperature  
 Output Overvoltage (Non Latching).

### ENVIRONMENTAL

Cooling: internal fans  
 Operating Temp: -40° to +60°C  
 Storage Temp: -55° to +85°C  
 Humidity: 0-95% non-condensing  
 Safety Agency: UL, CSA, TUV/CE (pending).

### MECHANICAL

Package Options: 1U or 2U Shelf Mount  
 Terminations: Power Connector  
 Weight: 670 g ( 1.47 lbs )  
 Size: 43.7mm x 86mm x 279mm  
 1.72" x 3.35" x 10.98"

## OUTLINE

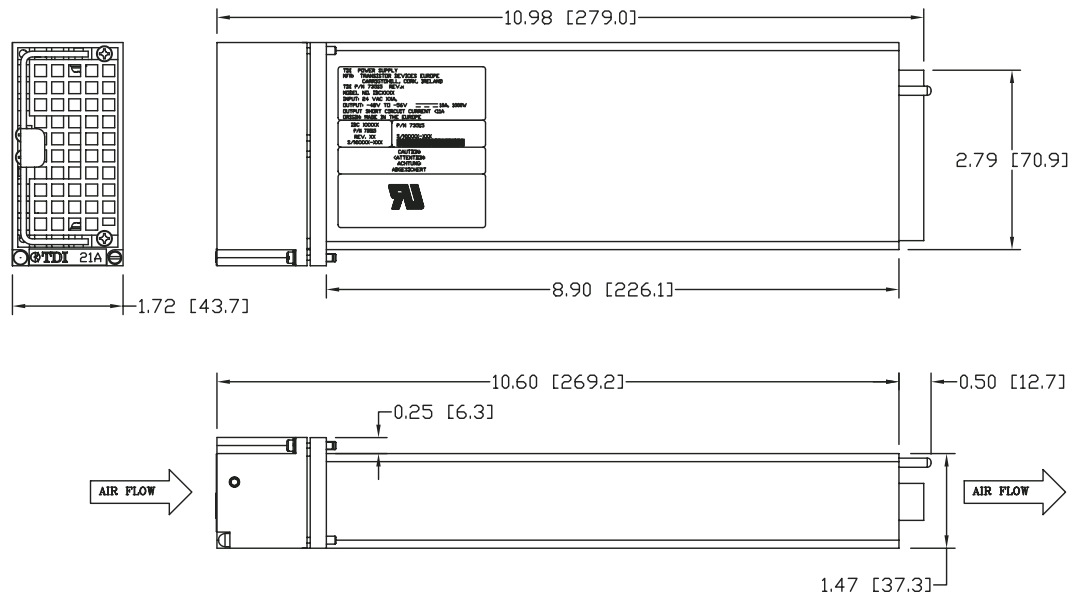

## STANDARD MODULE CONFIGURATION

Configuration Number	Part Number
IBC1K-24-48	73515

## SHELF PART NUMBERS

Description	Part Number
1U 3 Position Shelf with circuit breakers (3 Across Shelf Configuration)	73531
2U 8 Position Shelf (8 Across Shelf Configuration)	73476

Note 1U Shelf (73404) can also accommodate a maximum of four circuit breakers.  
 Max breaker size is 50Amps.

## POWER SHELVES

The IBC can be fitted into a 1RU or 2RU power shelf. The power shelves can be configured to include both distribution and control options. TDI offers two standard shelves and can also design a shelf specific to your application. Each Power Shelf includes a configurable Signal Interface Board (SIB). The SIB can be configured so that the IBC shelf alarming and control complements the battery plant controller. With both standard and custom options, the IBC shelf can be made interoperable with most DC power plant controllers.

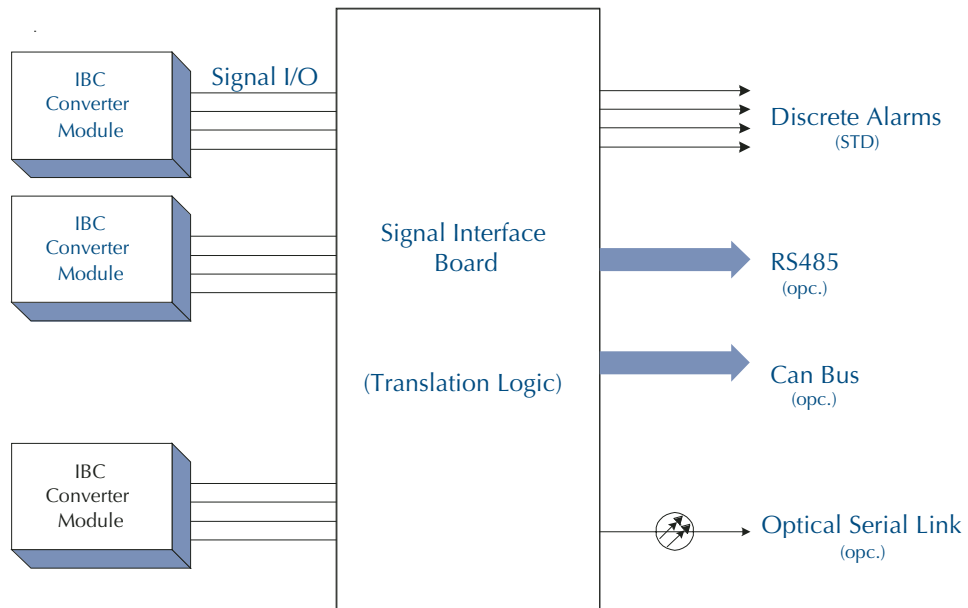

Signal Interface Board: Optional Interface logic

## 2RU SHELF OUTLINE

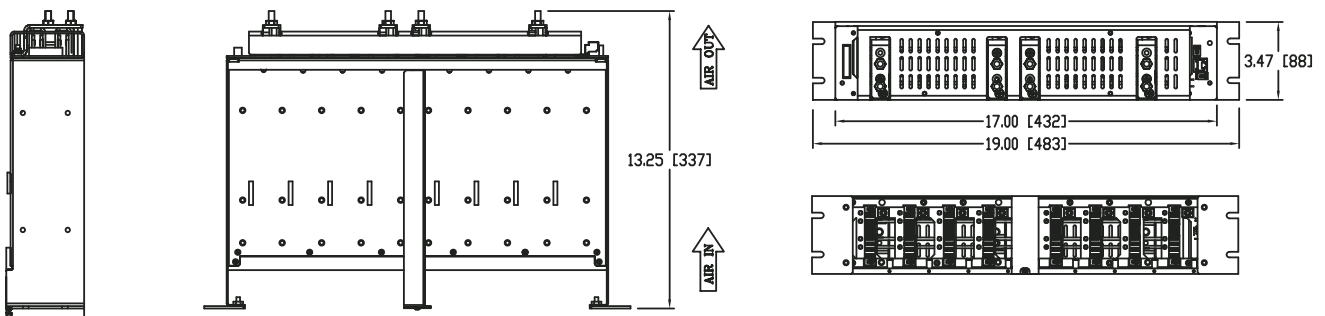

## APPLICATION OVERVIEW

The IBC Series is a family of hot-swappable, high efficiency converters designed specifically for wireless telecommunications applications including:

- GSM overlay
- Radio Transceivers in cell sites
- Microwave repeater sites
- Telecommunications gear in cell sites

The power shelves are designed with an application specific Signal Interface Board (SIB). The SIB can be configured so that the control and monitoring will work with most DC power systems deployed today. This makes the IBC shelf Interoperable with competitive DC Power Systems.

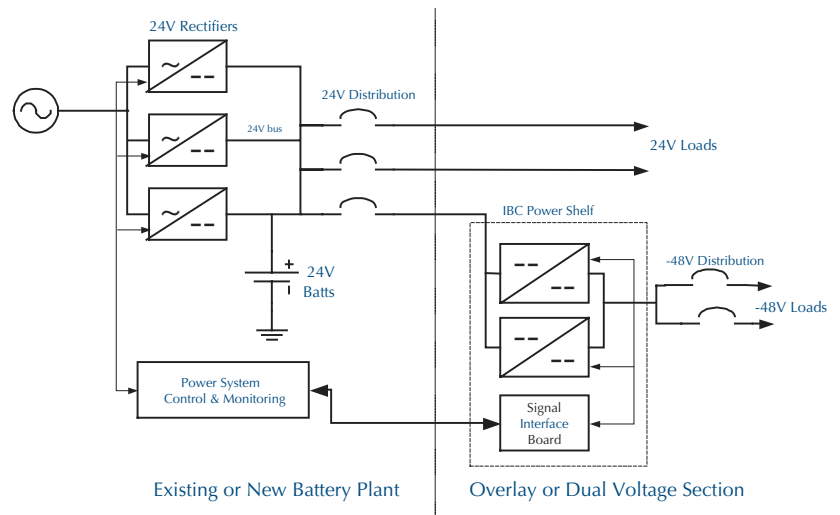

## EFFICIENCY

The IBC Series deploys state of the art multi stage switching techniques to make use of today's most advanced MOSFET technologies. Soft switching and synchronous rectification control is utilized resulting in a compact, efficient and reliable product.

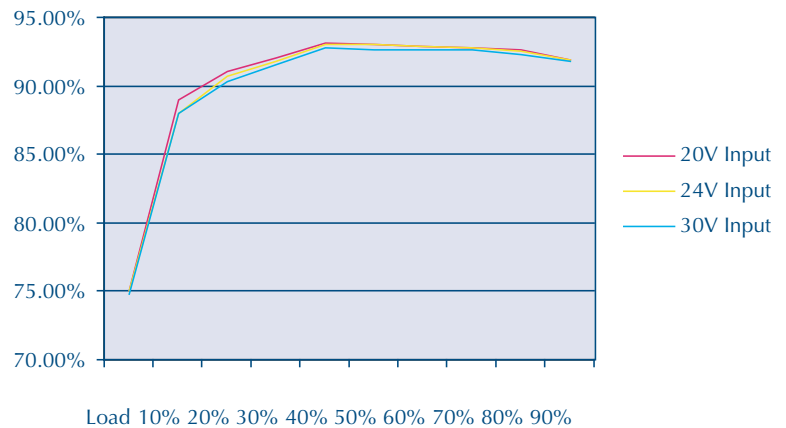

## TDI - TRANSISTOR DEVICES

**NORTH AMERICA:** 36A Newburgh Rd., Hackettstown, NJ, 07840 • P: 908.979.0088 • F: 908.850.1607

**EUROPE:** Carrigtwohill Industrial Estate, Co. Cork Ireland • P: +353.21485.3020 • F: +353.21.488.2131

**ASIA:** Transdev Electronics (Shenzhen) Co. Ltd • Phone: +86.755.6683367 • Fax: +86.755.6688797  
Room C-D 4/FL, Zhen Xing Bldg., Shekou Ind. Area, Shenzhen City, China 518067

**MIDDLE EAST, AFRICA, SOUTH AMERICA:** Allan Butler • allan\_butler@tdipower.com  
36 Newburgh Road, Hackettstown, NJ 07840 • P: 908.850.5088 • F: 908.850.1607